

CONTECA™ heat energy meter



7504 series



01306/22 NA
Replaces 01306/20 NA



Product range

CONTECA Heat meter kit, complete with heat meter, two integral temperature sensors, two sensor holder bodies and rotary pulse flow meter, and :

7504_0A series	male NPT pipe connections	_____	sizes ½", ¾" & 1" with unions
7504_3A series	female NPT pipe connections	_____	sizes 1", 1¼" & 1½" with unions
75041_A	ANSI Class 150 RF flange connections	_____	sizes 2½" to 8"
7504_6A series	press pipe connections	_____	sizes ½", ¾" & 1" with unions
7504_9A series	sweat pipe connections	_____	sizes ½", ¾" & 1" with unions
Code 750450	Datalogger		
Code 755052	Modbus-to-BACnet gateway		

Technical specifications

Heat meter:

Materials: -Housing & cover:	ABS, RAL 9004
Power supply:	24 VAC, 50/60 Hz, 1W
Data transmission:	2-wire RS485; selectable Modbus or M-bus (for use with datalogger)
Ambient temperature:	40 — 113°F (4— 45°C)
Environmental rating (protection class):	NEMA 3S (IP 54)
Pulse inputs:	Class 1B per EN 1434-2
Certification:	ASTM E3137/E3137M-17 by ICC-ES Directive 2014/32/EU EN 1434 (MI 004)
Approved for thermal energy measurement for Canada, Approval # AV-2474C	

Temperature sensors:

Cable length*:	26¼ ft. (8 m)
Sensor type:	100 kOhm NTC matched
Temperature range: heating mode:	50—195°F (10— 90°C)
Temperature range: cooling mode:	35—77°F (2— 5°C)
Temperature sensitivity:	< 0.1°F (0.05°C)
Temperature sensor thermowell:	Stainless steel
Sensor holder body:	Brass
Max. working pressure:	150 psi (10 bar)

*Extra length of the 26¼ ft. cable must be carefully coiled and mounted in a safe place. Do not cut or splice.

Function

CONTECA™ is a direct heat energy meter designed to measure and record thermal energy usage in residential and commercial buildings, for heating only, cooling only, or both heating and cooling.

The CONTECA meter features an 8-digit liquid crystal display that enables easy reading of BTU consumed as well as a range of technical data indicating equipment operating status and logged data.

Each CONTECA includes a heat meter with an electronic calculator and user interface, two temperature sensors, and sensor holder bodies, fittings included. The rotary pulse flow meter comes with the CONTECA meter kit. In addition to the two temperature inputs and flow meter input, 4 additional pulse inputs are available for optional equipment monitoring. Data logging is integral and menu accessible in each CONTECA. Multiple units can be connected to the CONTECA Datalogger for access to all units on the network. The CONTECA is easy to install and commission, and is certified to ASTM E3137/E3137M-17 Standard Specification for Heat Meter Instruments by ICC-ES, and Directive 2014/32/EU EN 1434 (MI 004). Also, approved for thermal energy measurement by the authority of the Minister of Industry (styled Innovation, Science and Economic Development) of Canada, Approval number AV-2474C.

The CONTECA heat meter has integral RS485 protocol 2-wire communication for remote access and configuration. M-bus protocol is used with the CONTECA Datalogger (default). The protocol can be changed to Modbus when using the CONTECA heat meter directly with a Modbus BAS or when using the Modbus-to-BACnet gateway for communication to a BACnet BAS. Up to 250 CONTECA meters can connect to one CONTECA data logger.

Flow meters:

Flow meter type:

Single jet (½" - 1" to 10 gpm); Multiple jet (1" to 1½" to 45 gpm);
Woltman (2½" - 8" to 1000 gpm)

Body material: Brass (½" - 1½"); Powder-coated cast iron (2½" - 8")

Pulse output: class OA-OC in accordance with EN 1434-2

Body threads (brass bodies): ISO 228 male straight

Piping connections: Brass: Dual unions, tailpieces NPT, sweat, press

Cast iron: ANSI Class 150 RF flanged

Max. working pressure:

Brass & Cast Iron: 235 psi (16 bar)

Maximum fluid temperature:

265°F (130°C)

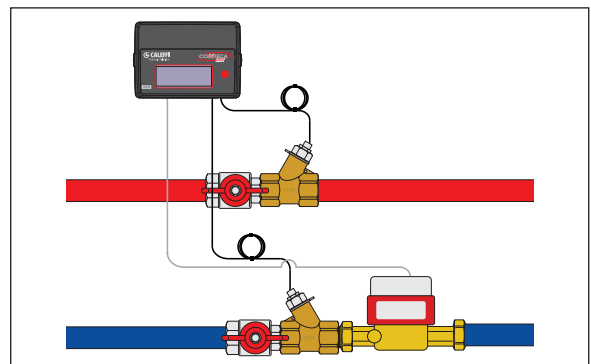

Dimensions

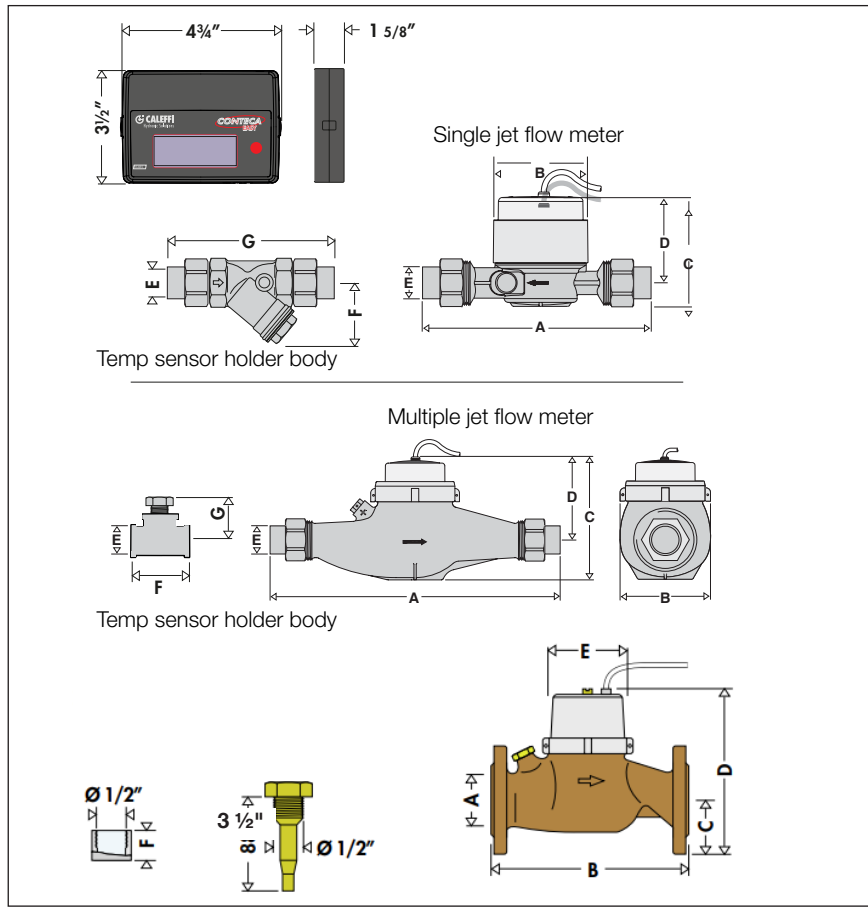

Code	A	B	C	D	ends*	E	F	G	Wt (lb)
750449A	6 7/8"	3 1/8"	4 1/4"	3 1/2"	sweat	1/2"	7 1/4"	2"	6.2
750440A	8 3/8"				8 3/4"				
750446A	7 1/2"				4 7/8"				
750459A	7 3/8"				7 3/4"	3/4"	7.1		
750450A	7 5/8"				8"				
750456A	7 7/8"				8 1/4"	1"	7.9		
750469A	8 5/8"				9"				
750460A	8 3/8"				8 3/4"				
750466A	8 5/8"				8 1/2"	1"	6.0		
750405A	5 1/8"				5 1/8"				
750463A	12 1/4"	4"	5 3/8"	3 3/4"	fnpt	1"	5 1/8"	2 1/16"	11.5
750473A	12 1/4"	4"	5 3/8"	3 3/4"		1 1/4"	5 7/8"	2 3/8"	12.1
750483A	17 1/4"	5 1/4"	6 7/16"	4 5/8"		1 1/2"	5 5/8"	2 5/16"	18.7
750410A	2 1/2"	7 7/8"	3 3/8"	8 7/8"	flange	6"	1 5/16"	27	
750411A	3"	8 7/8"	3 3/4"	9 1/4"		6"	1 5/16"		29
750412A	4"	9 7/8"	4 5/16"	12 1/4"		8 5/8"	1"		44
750413A	5"	9 7/8"	5"	12 3/4"		9 7/8"	3/4"		51
750414A	6"	11 13/16"	5 5/16"	15"		11 1/4"	3/4"		88
750415A	8"	13 13/16"	6 1/2"	16 1/8"		13 3/8"	3/4"		110

*end connections are the same for the flowmeter and sensor holder bodies for each code, except for flanged codes.

Flow rates

Code	Size	Flow meter type & code	Liters per pulse	Minimum Flow rate (gpm)	Maximum flow rate (gpm)
Single jet					
75044xA	1/2"	750405	1	0.25	10
75045xA	3/4"				
75046xA	1"				
Multiple jet					
750463A	1"	750406	2.5	0.3	15
750473A	1 1/4"	750407	10	0.5	25
750483A	1 1/2"	750408		1	45
Woltman					
750410A	2 1/2"	750410	100	11	110
750411A	3"	750411		14	140
750412A	4"	750412		22	220
750413A	5"	750413		35	350
750414A	6"	750414	1,000	88	880
750415A	8"	750415		100	1000

Flow rate range for combined flow meter and 2 sensor holder bodies.

Hydraulic characteristics

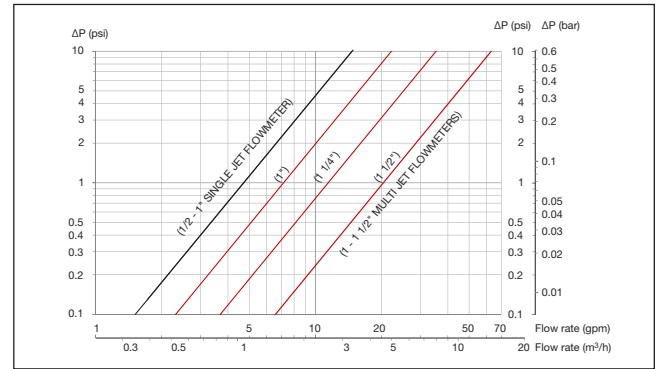

	Single jet flow meter			Multiple jet flow meter		
	1/2"	3/4"	1"	1"	1 1/4"	1 1/2"
Cv	5.0			6.8	11.7	19.6

Flow rate range for combined flow meter and 2 sensor holder bodies.

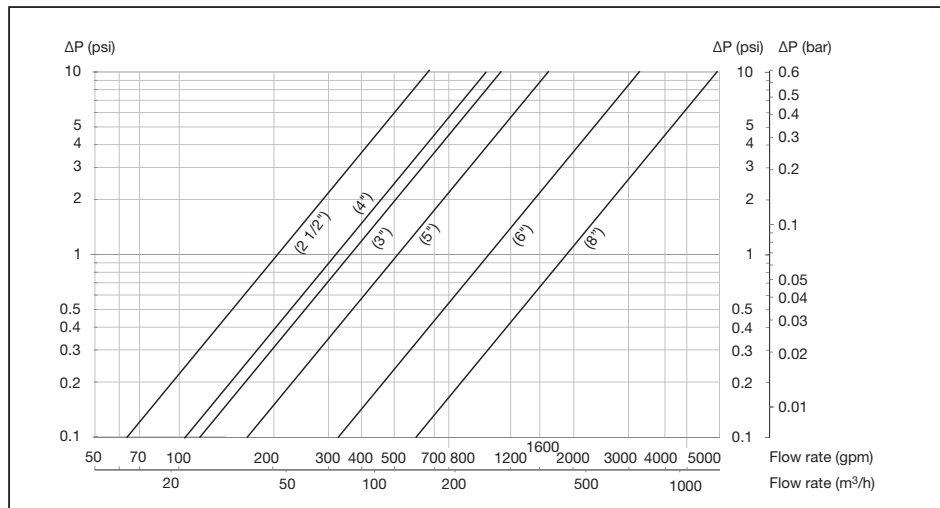

	Woltman meter					
	2 1/2"	3"	4"	5"	6"	8"
Cv	208	370	330	522	1,030	1,970

Flow rate range for combined flow meter and 2 sensor holder bodies. Note, the 4" meter flow capacity is lower than the 3" meter.

Installation

To ensure accurate energy measurement, plan the installation for easy initial installation, commissioning and future maintenance. Install the flow meter in a location that will be easy to perform periodic maintenance.

Install shut-off valves upstream and downstream of the flow meter to aid installation and maintenance. Install a strainer or other filtering device upstream of the flow meter.

Install the temperature sensor thermowells into the brass sensor holder bodies, following the respective flow directions and properly located for the supply (red label) and return (blue label) positions. The corresponding supply and return pipes must be integral to the same flow rate as measured by the flow meter.

Sensor cables are factory pre-wired. Do not modify the length of the sensor cables. The sensor cables must not be spliced for shortening or extending because this will adversely affect functionality and accuracy. Coil up excess cable and secure in safe place to prevent damage.

The flow meter must be installed on the return pipe and in the horizontal position with the turbine axis vertical (meter facing upward), following the flow direction indicated by the arrow on the body.

After installing all CONTECA heat meter kit components follow the electrical connections instructions.

When installation is completed all components need to be lead sealed. Follow the provided lead sealing procedure in the instructions include product package .

1) Diagram of system with metering on manifold with several stages.

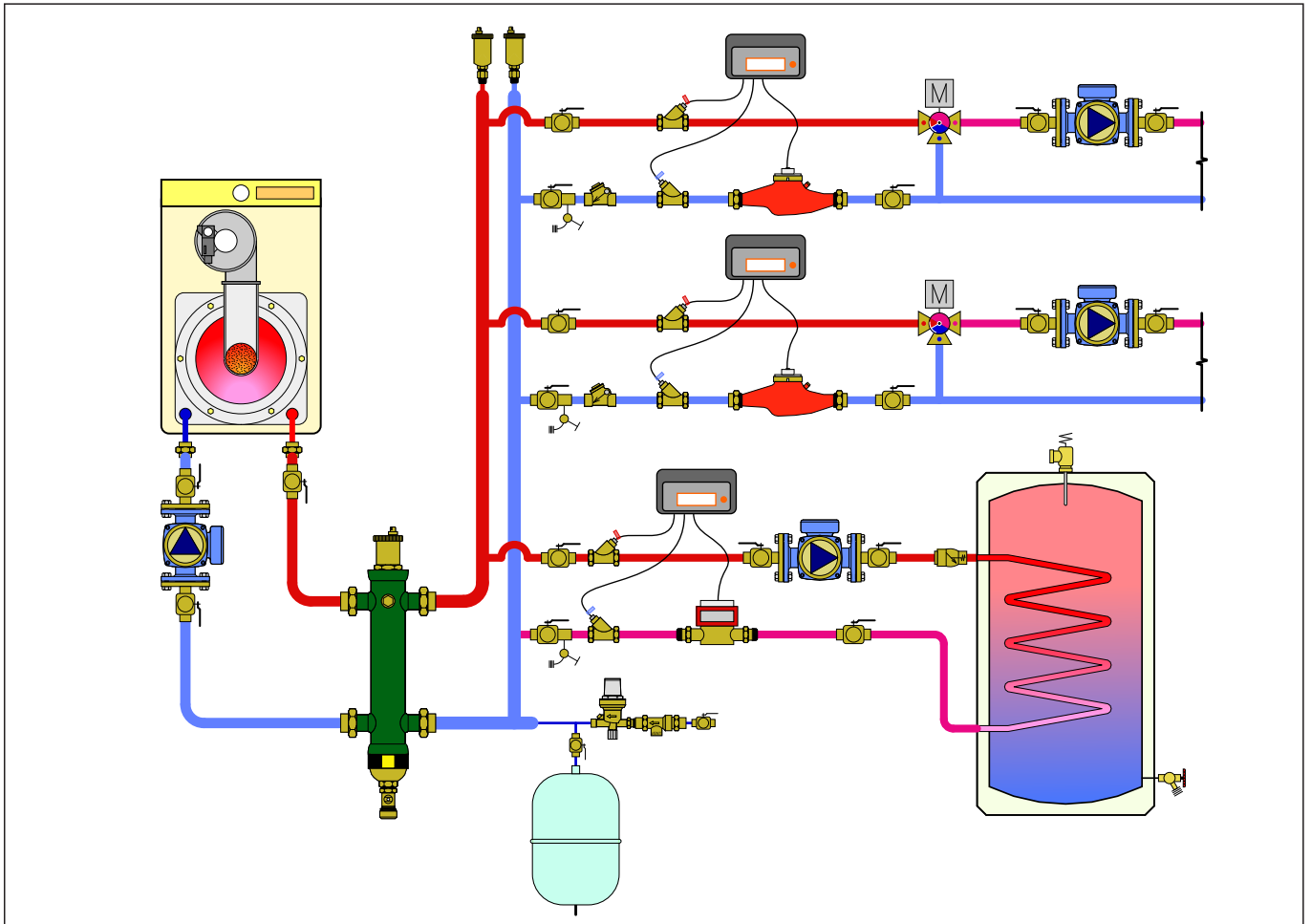

2) Diagram of user circuit - Control with 2-way zone valves

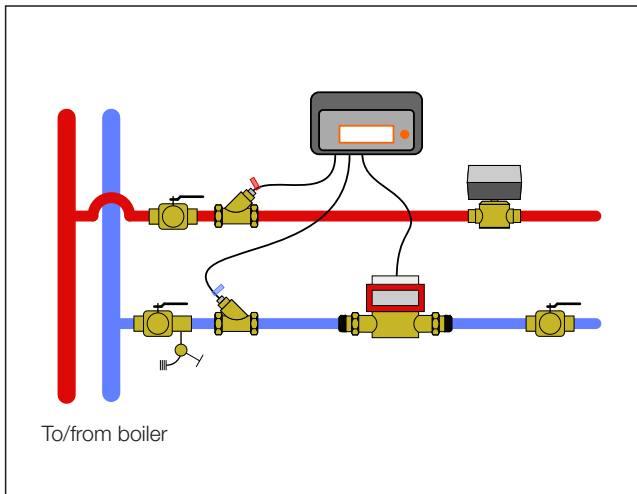

When mounting in a box or directly on a wall, use the screws provided in the package and insert them in the slots (A) to mount correctly. Disassemble the user interface from the wiring base by releasing the side locking tabs (B) to access the wiring terminal pins. After connecting the desired wiring, re-assemble the heat meter by connecting the user interface to the wiring base, making sure the pins line up to avoid bending any pins.

Sensors are pre-wired to the circuit board, no connections for the sensor are made on the wiring terminal.

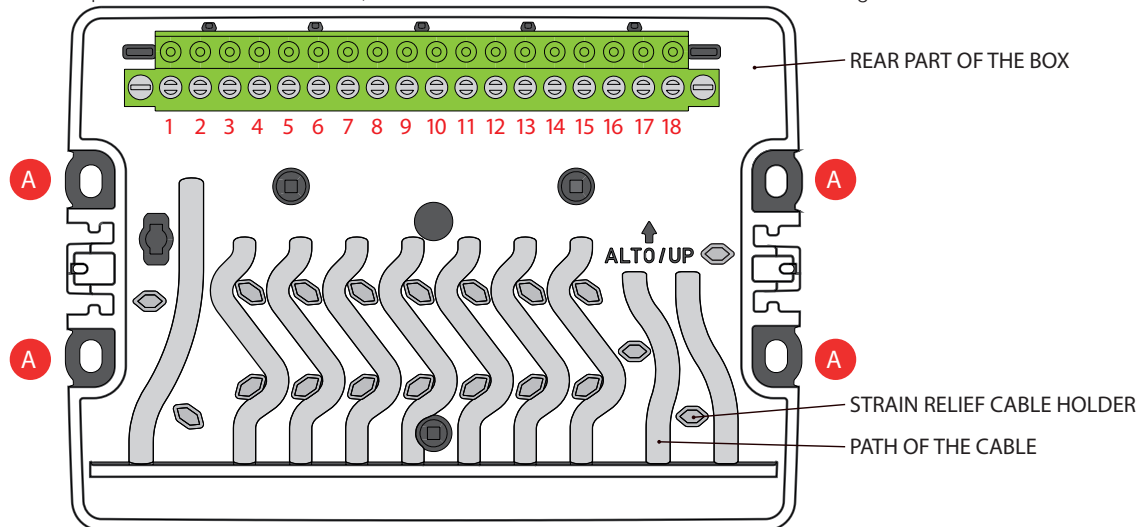

Pins	Description
1 - 2	OUT 2 - Open collector pulse output for COOLING units. GND=2 / duration 120 ms / Vmax 24V (dc) - 50 mA
2 - 3	OUT 1 - Open collector pulse output for HEATING units. GND=2 / duration 120 ms / Vmax 24V (dc) - 50 mA
4	NOT used
5 - 6	IN 4 - 4th pulse input (generic). GND=6
6 - 7	IN 3 - 3rd pulse input (generic). GND=6
8 - 9	IN 2 - Pulse input for optional DCW. GND=9
9 - 10	IN 1 - Pulse input for optional DHW. GND=9
11 - 12	Pulse input for the heating volume meter
13 - 14	Digital input (Dry contact: it must be a volt free contact)
15 - 16	Power supply 24 V (ac) 50 / 60 Hz - 1W
17 - 18	Transmission Bus RS-485 / RS-485 A=18 (Rx) RS-485 B=17 (Tx)

• Power supply and energy flow meter inputs

- 15 - 16 Power supply 24 V (AC).
- 11 - 12 Flow meter pulse input.

The 24 V (AC) electric supply line should be used solely for the heat meters.

• Network connection

In the case of data transmission via bus use the following terminals:

- 17 - 18 Polarized transmission bus - Bus RS-485
- 17 Tx (RS-485-B) 18 Rx (RS-485-A)

For the transmission bus, use a shielded 2-conductor AWG 22.

Note: The transmission polarity must be fully observed.

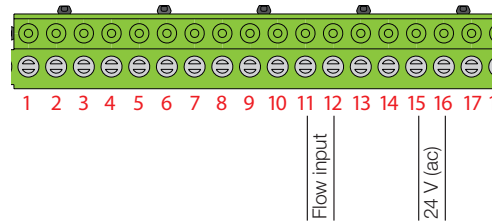

(Pin 4 is not used)

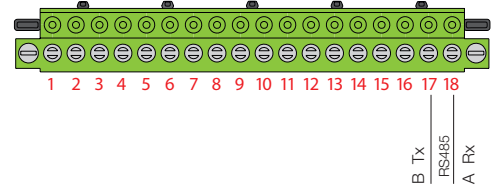

• Energy pulse outputs

- 2 - 3 Heating units output to remote data gathering device (kBTU)
- 1 - 2 Cooling units output to remote data gathering device (kBTU)

Output specifications:

1 PULSE = 1 kBTU - open collector contact

Pulse duration: 120 ms

Max. frequency - 1 Hz

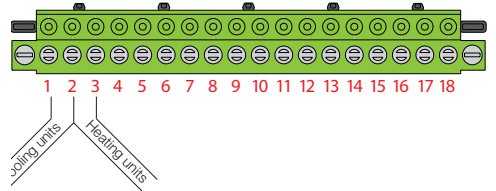

• Domestic hot and cold water inputs

Separately sourced domestic water meter with pulse outputs.

- 8 - 9 Pulse input for optional DCW (gal)

- 9 - 10 Pulse input for optional DHW (gal)

1 PULSE = 1 gal

Pulse duration: 120 ms

Max. frequency - 1 Hz

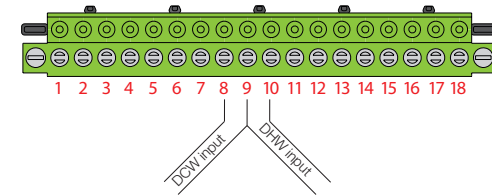

• Additional pulse inputs

ie: Watt Hour meter - Gas meter

The metering system must be provided with a volt free contact and the weight of the pulse must be indicated.

1 Pulse = 0.1 kWh electric energy

1 Pulse = 1 Nm³ gas

- 6 - 7 3rd pulse input

- 5 - 6 4th pulse input

Minimum pulse duration: 120 ms

Max. frequency - 1 Hz

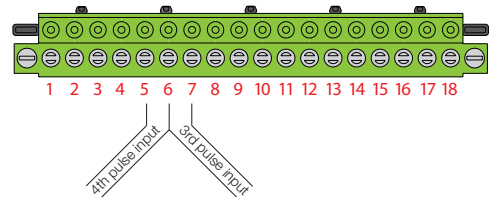

• Digital input

The digital input must be potential free (class IB).

- 13 - 14 Connection of the auxiliary microswitch of the zone valve (ON/OFF status). When in the ON status an internal register logs the hours of circuit operation. This input does not affect the meter calculations or function.

Notes: - Each 7504 series device is supplied with a tamper-proof lead sealing kit for the temperature probes and for the plastic electronics box.

- Make the cables to pass through the cable fairleads and the strain relief cable holders. The basic function of the partition is to protect the electronics card from dust and jets of water.

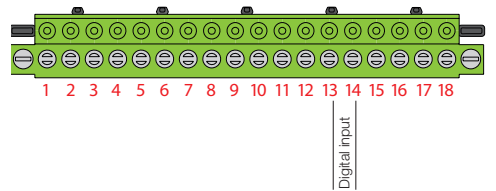

Operating information

The accumulated energy amounts are retrieved in a non-volatile memory device (EEPROM) each time the units of measurement are completed (1 BTU) and, at the same time, this increase causes the display to be updated (see "User information cycle").

User information cycle

The CONTECA heat meter has a liquid crystal display. The display is activated by pressing the button on the front. Scroll through the various information windows by repeatedly pressing the button briefly. In some views, holding the button for several seconds allows additional information to be shown on the display.

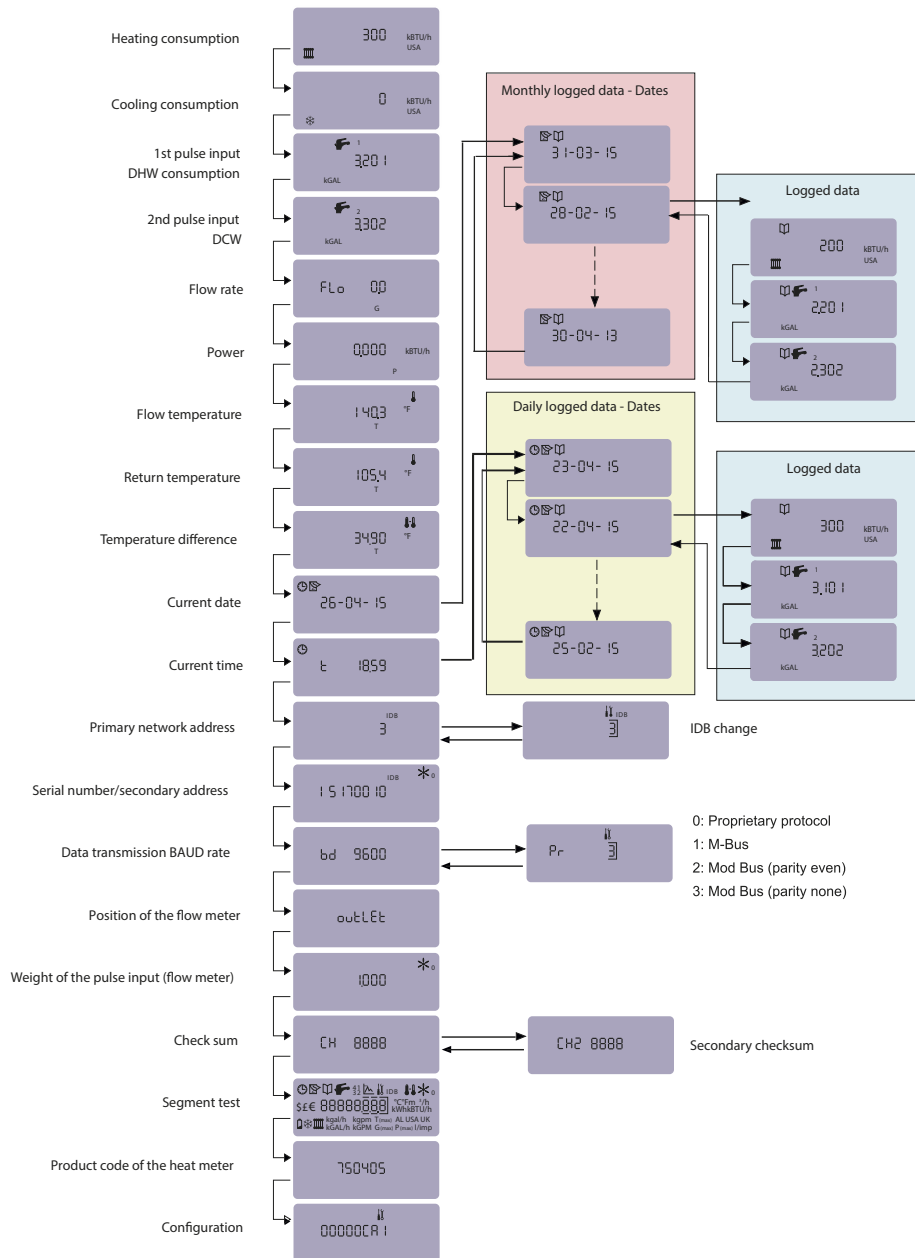

Contact Caleffi for the special procedure to configure CONTECA for measuring heat energy of fluids other than water, such as glycol.

User information details

- A. Heating Consumption is a calculated totalization of heating energy (BTUs). Heating is calculated only when supply temperature is above 72°F (factory set). There is also a fixed minimum temperature difference of 0.7°F (deadband) below which no BTU calculation takes place.
- B. Cooling Consumption is a calculated totalization of cooling energy (BTUs) Cooling is calculated only when supply temperature is below 64°F (factory set).
- C. 1st pulse input DHW is a totalized value of DHW consumption (kGal), if used
- D. 2nd pulse input DCW is a totalized value of DCW consumption (kGal), if used
- E. 3d and 4th pulse inputs are totalized values for those inputs, if used
- F. Flow rate is the instantaneous GPM at the flow meter
- G. Power is the instantaneous energy usage (kBTU/hr) calculated by the meter
- H. Flow (supply) temperature, return temperature, and temperature difference are current values
- I. Current date is also the entry point to Monthly Logged Data (hold button for 10 sec). Select the month desired and the display will show the totalized heating energy, cooling energy, flow volume and the 4 pulse inputs for the selected month
- J. Current time is also the entry point to Daily Logged Data (hold button for 10 sec). Select the day desired and the display will show the totalized heating energy, cooling energy, flow volume and the 4 pulse inputs for the selected day
- K. Primary Network address is used when multiple CONTECA are connected, each must be unique when using a network application
- L. Serial Number/Secondary address is a unique identifier and cannot be changed
- M. Data transmission BAUD rate is 9600 baud and is the entry point for the communication protocol (if network is used). Set to 1, M-bus, if using a CONTECA™ Datalogger and set to 2 or 3 if using Modbus and/or the Modbus-to-BACnet gateway.
- N. Position of the flow meter defaults to "outlet" or return pipe. All BTU calculations assume the meter is mounted on the return pipe; this can be changed if necessary; consult Caleffi.
- O. Weight of the pulse input flow meter is volume per pulse
- P. Checksum is for information only
- Q. Segment test allows the user to make sure all the elements in the display are functional
- R. Product Code is the base model of the meter itself
- S. Configuration is the version of the firmware in the meter

Building transmission network layout

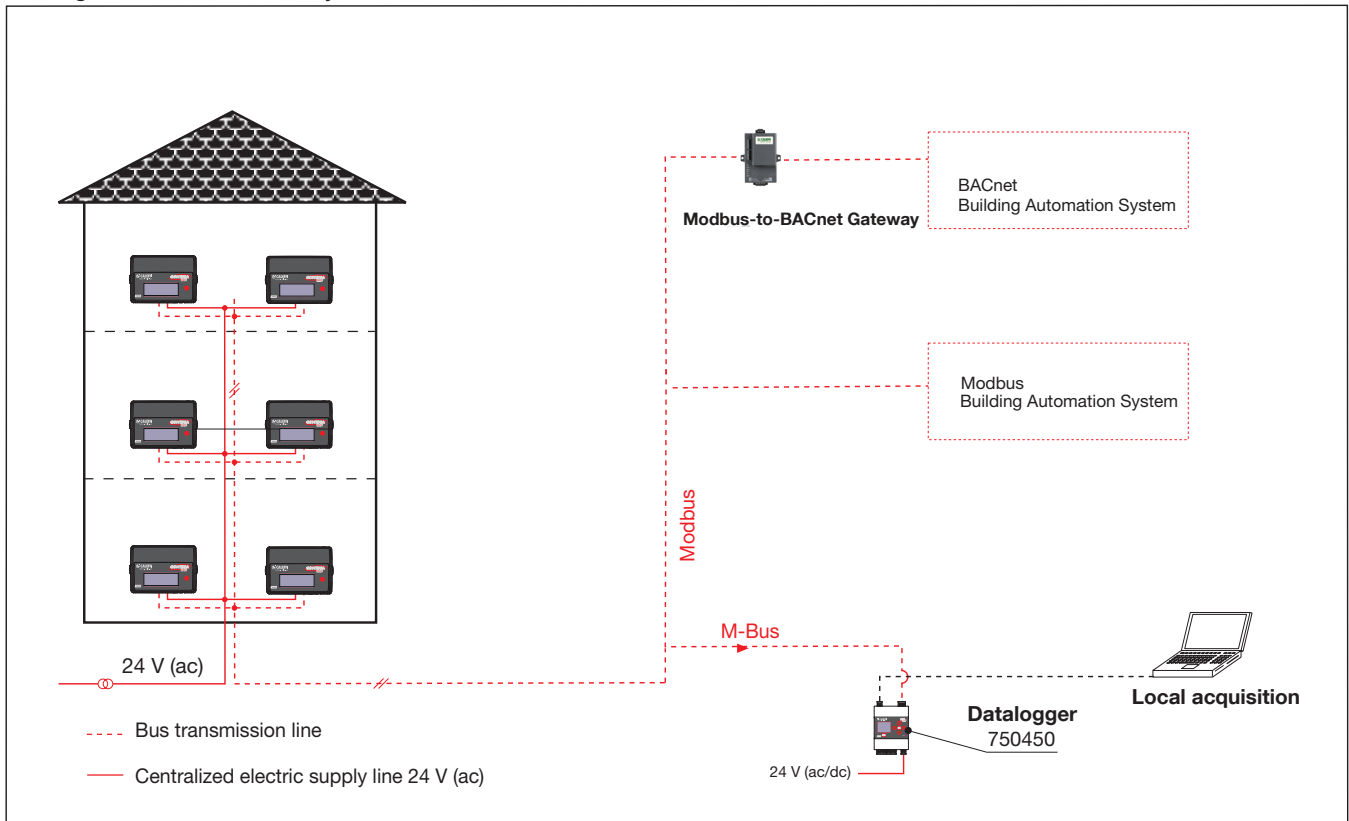

Lead sealing

The CONTECA heat meter package contains lead sealing components for the temperature sensors and the heat meter.

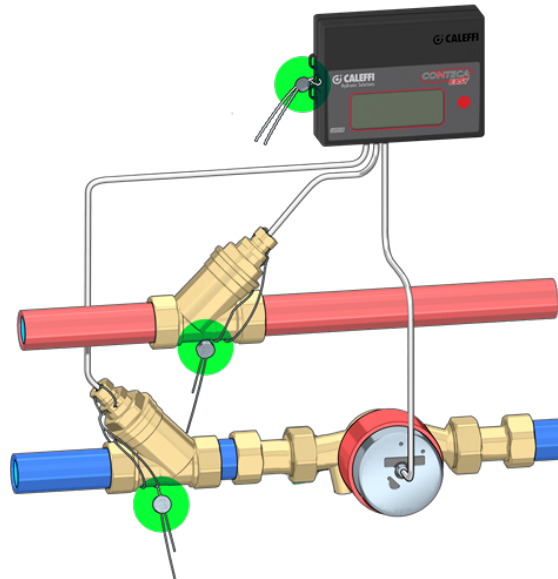
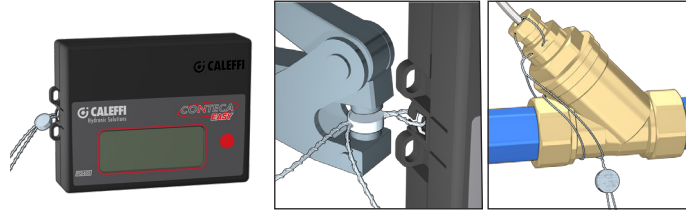

750450 CONTECA Datalogger

The CONTECA datalogger allows acquisition and logging of the consumption data from CONTECA heat meters via M-Bus communication. The integrated browser provides logged and instantaneous data, and report generator. The CONTECA datalogger can be set up locally via web interface by connecting a PC to one ethernet port with switch functionality.

The SMART function allows the automatic detection of the heat meters connected to the network. Data can be obtained with the automatic report generation, making the system user-friendly and reduces the number of operations to run.

Maximum number of heat meters: 250.



Main specifications of the datalogger:

- Power supply: 24 V (dc) ±10%, 24 V (ac) - 3 W.
- 2 Ethernet ports: ETH1 (PoE), ETH2.
- Ambient temperature range: 32 - 122°F.
- Mounting: on a 35 mm DIN rail (EN 60715).
- Daily data logging: 10 years.
- Reports: In XLS or CSV format.

755052 Modbus-to-BACnet gateway



Converts CONTECA controller Modbus (RS-485 serial) output communication to BACnet IP or MSTP communication.

NA605010 Wall mount transformer



Input voltage: 120 V AC.
Output voltage: 24 V AC.
Power output: 40 VA.
Agency approval: cULus.

V40 Replacement flow meter

Replacement flow meter (body only).

Single jet and Multiple jet rotary pulse flow meter measures liquid flow for energy heat metering production or consumption. Accurate to International Standards OIML, R75, EN1434 and MID. Brass body. Sweat connections included.

Working temperature range: -40 to 210°F.

Maximum fluid temperature: 265°F.

Maximum working pressure: 235 psi.

Maximum glycol: 50%.

Code	Description	Weight (lb/kg)
R79701	Single jet, 1/2" - 1", 0.25 to 10 GPM	3.0/1.4
R79702	Multi-jet, 1" only, 0.3 to 15 GPM	5.0/2.3
R79703	Multi-jet, 1 1/4" only, 0.5 to 25 GPM	8.0/3.6
R79704	Multi-jet, 1 1/2" only, 1.0 to 45 GPM	14.0/6.4



SPECIFICATION SUMMARY

CONTECA Series 7504

Direct heat energy meter for heating and cooling systems. **Heat meter:** 8-digit liquid crystal display. Power supply 24 VAC - 50/60 Hz, power consumption 1 W. Data transmission 2-wire RS485; selectable Modbus or M-bus (for use with Datalogger). Ambient temperature range 40°F to 113°F (4°C to 45°C). Environmental rating (protection class) NEMA 3X (IP54). Pulse inputs Class 1B per EN 1434-2; two temperature inputs, one flow meter input, and 4 additional inputs. Certified to ASTM E3137/E3137M-17 Standard Specification for Heat Meter Instruments by ICC-ES, and Directive 2014/32/EU EN 1434 (MI 004). Approved for thermal energy measurement by the authority of the Minister of Industry (styled Innovation, Science and Economic Development) of Canada, Approval number AV-2474C. **Temperature sensors:** Cable length 26.25 feet (8 meters). 100 kOhm NTC matched sensors. Temperature sensitivity <0.1°F (0.05°C). Stainless steel temperature sensor thermowell and brass sensor holder body. Maximum working pressure 150 psi (10 bar). **Rotary pulse flow meter:** Brass body with sweat, press or NPT male connections, 1/2", 3/4" or 1" single jet turbine flow meter, flow rates 0.25 gpm to 10 gpm; NPT female 1", 1 1/4" and 1 1/2" multiple jet turbine flow meter, flow rates 0.3 gpm to 45 gpm. Maximum working pressure 235 psi (16 bar). Maximum fluid temperature 265°F (130°C). **Powdercoated Cast Iron** body with ANSI Class 150 flanges, 2 1/2 to 8" woltman flow meter, flow rates 11 gpm to 1000 gpm. Maximum working pressure 235 psi (16 bar). Maximum fluid temperature 265°F (130°C). Pulse output class OA-OC in accordance with EN 1434-2. Equipped with lead seals to prevent tampering. Provide with optional Datalogger, code 750450 and, if needed, code NA10520 Modbus-to-BACnet gateway. Provide with wall mount transformer, code NA605010.

Code 750450

Datalogger for BTU usage data acquisition and logging. Communication via RS-485 physical layer in M-Bus protocol. Power supply 24 V (dc) - 3 W or 24 V (ac) - 3 W. Integrated web interface. Daily data logging: 10 years. Mounting on a 35 mm DIN rail (EN 60715). 2 Ethernet ports. Reports in .XLS or .CSV format. Maximum number of heat meters connected 250. Ambient temperature range 2°F to 122°F (4 to 50°C).

Code NA10520

Modbus-to-BACnet gateway. Modbus RS-485 serial output to BACnet IP or MSTP communication.

We reserve the right to make changes and improvements to the products and related data in this publication, at any time and without prior notice.



Caleffi North America, Inc.
3883 W. Milwaukee Road
Milwaukee, WI 53208
Tel: 414-238-2360 · Fax: 414-238-2366
sales@caleffi.com · www.caleffi.com
© Copyright 2022 Caleffi North America, Inc.